



# User Manual

# TGPower

Home Energy Storage System  
Wall-mounted Battery Solution

**TGP-BAT-LV51-16**

EN Version 1.1

Date 2026-05-25



---

**Copyright © TuroGize Inc. All rights reserved.**

No part of this document may be reproduced or transmitted in any form or by any means without the prior written consent of TuroGize Inc.

### **Notice**

The purchased products, services, and features are stipulated by the contract made between TuroGize and the customer. All or part of the products, services, and features described in this document may not be within the purchase scope or the usage scope. Unless otherwise specified in the contract, all statements, information, and recommendations in this document are provided "AS IS" without warranties, guarantees, or representations of any kind, either express or implied.

This manual does not replace local electrical code requirements.

Installation, wiring, and commissioning must comply with all applicable national and local electrical codes, including the Canadian Electrical Code (CEC) and provincial/territorial regulations.

This product carries UL certification for product safety; installation compliance must be verified by licensed electricians and local authorities having jurisdiction (AHJ).

This manual is supplementary. In all cases, local regulations and AHJ requirements take precedence.

The information in this document is subject to change without notice. Every effort has been made in the preparation of this document to ensure the accuracy of the contents, but all statements, information, and recommendations in this document do not constitute a warranty of any kind, express or implied.



---

# Contents

<b>About This Document .....</b>	<b>1</b>
<b>1 Introduction .....</b>	<b>2</b>
1.1 Application .....	2
1.2 Product Appearance.....	2
1.3 Panel Introduction.....	3
1.4 PIN Definition .....	5
1.5 Technical Specifications.....	6
1.6 Recycling and Disposal .....	7
<b>2 Installation .....</b>	<b>8</b>
2.1 Precautions for Installation .....	8
2.2 Installation Preparation.....	8
2.2.1 Tools Preparation .....	8
2.2.2 Packing List.....	9
2.2.3 Unpacking and Inspection.....	10
2.3 Installation.....	10
2.4 Recommended Configuration .....	12
2.5 Cable Connection .....	12
2.5.1 Power Cables Connection .....	12
2.5.2 Communication Cable Connection .....	13
2.5.3 120Ω Resistor Connection.....	14
<b>3 Parallel Connection.....</b>	<b>15</b>
<b>4 Make System Run .....</b>	<b>18</b>
4.1 Check before Running .....	18
4.2 Power-on .....	18
4.3 Power-off.....	19
<b>5 Maintenance .....</b>	<b>20</b>
5.1 Battery Storage.....	20
5.2 Monthly Maintenance.....	21
5.3 Quarterly Maintenance .....	21
5.4 Yearly Maintenance.....	21
<b>6 Shipment.....</b>	<b>22</b>
<b>7 Troubleshooting .....</b>	<b>23</b>
<b>8 Warranty.....</b>	<b>24</b>
<b>Abbreviations .....</b>	<b>25</b>



# About This Document

## Overview

This user manual primarily introduces the main features, component composition, usage, installation, and maintenance of TGPowerr TGP-BAT-LV51-16 product for technical support engineers, maintenance engineers and users.











## Reader

This document is mainly applicable to the following people:

- Technical support engineers
- Maintenance engineers
- Installation personnel
- Users

## Signs

These signs that may be found in this user manual are defined as follows.

Sign	Meaning &Description
	Danger: Indicates a hazard with a high level of risk that will cause death or serious injury if not avoided.
	Warning: Indicates a hazard with a moderate risk that may cause death or serious injury if not avoided.
	Notice: Indicates a hazard with a low level of risk that may cause minor or moderate harm if not avoided.
	Explanation: Supplementary explanation of key information in the main text. "Explanation" is not safety warning information, and does not involve personal, equipment and environmental damage information.
	This marking indicates that this product should not be disposed of with other household wastes.
	Read the product and operation manual(instructions) before operating the battery system!
	Do not place near open flame.
	Recycle label.
	The certificate label for EMC.
	Warning electric shock.



# 1 Introduction

## 1.1 Application

TGP-BAT-LV51-16 is a new-generation product developed by TuroGize, which is used in residential energy storage solutions. This battery system has a capacity of 16.07 kWh.

TGP-BAT-LV51-16 integrates the high-performance BMS. It has multiple protection functions to extend battery life, such as system over-charge, system over-discharge, cell over-voltage, cell under-voltage, charging over-current, discharging over-current, and insulation fault protections. It also has RS485 and CAN communication to read battery module's real-time data.

## 1.2 Product Appearance

The appearance of TGP-BAT-LV51-16 is shown as follows.



Fig. 1 TGP-BAT-LV51-16 Appearance

The TGP-BAT-LV51-16 dimensions are shown as follows.

Model	Width (mm)	Depth (mm)	Height (mm)	Remark
TGP-BAT-LV51-16	500±1.5 (without cover)	250±1.5	860±1.5 (without bracket)	/

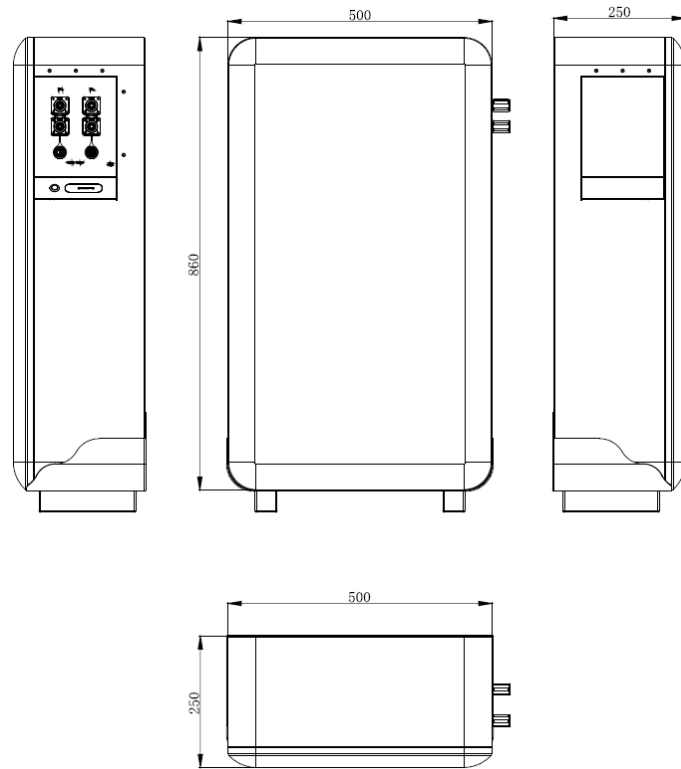

Fig 2. TGP-BAT-LV51-16 Dimensions (unit: mm)

### 1.3 Panel Introduction

The TGP-BAT-LV51-16 operation panel is shown as follows.

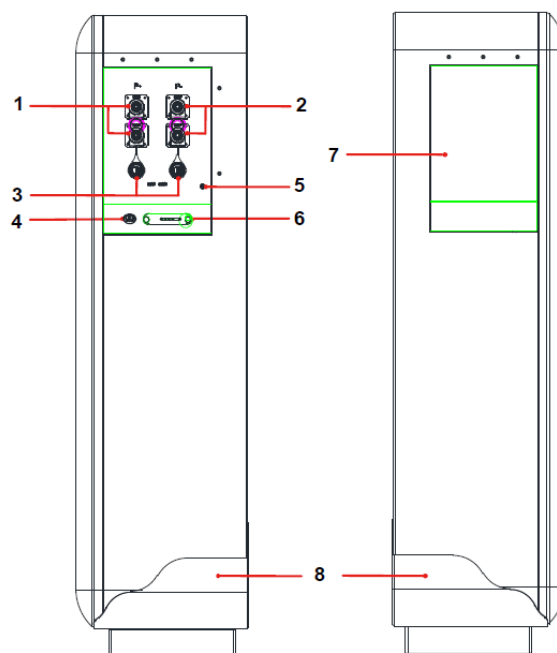

Fig 3. TGP-BAT-LV51-16 Operation Panel







The definition of the TGP-BAT-LV51-16 operation panel is shown as follows.

**Table 1. Operation Panel Interface Definition**

No.	Name	Description
1	P+ power terminal	Battery output
2	P- power terminal	Battery output
3	COM1/COM2	2*RJ-45 interfaces for RS485/CAN communication
4	Power switch	Power on/off button
5	GND	For battery grounding
6	LED	Indicate the battery capacity (SOC), run and fault status
7	Groove	For moving battery
8	Mounting Bracket	Used to stabilize the battery

The SOC indicator used to identify the current capacity status of the battery. The number of blinking indicators corresponds to different remaining capacity. The specific meaning is shown as follows.

**Table 2. The SOC Indicator Definition**

No.	Indicator	Description	Remark
1		$0% < SOC \leq 25%$	/
2		$25% < SOC \leq 50%$	/
3		$50% < SOC \leq 75%$	/
4		$75% < SOC \leq 100%$	/

The corresponding relationship between operation status and indicator status is shown as follows.



**Table 3. The Run(Green) Indicator Definition**

Flash mode	ON	OFF	Battery Status
Flash 1	1 s	2 s	Idle
Flash 2	2 s	3 s	Charge
Keep on	-	-	Discharge
Keep off	-	-	Sleep/Fault

**Table 4. The Alarm Indicator (Red) Definition**

Flash mode	ON	OFF	Battery Status
Keep on (Red)	-	-	Fault (Charge/Discharge MOS, NTC, 1818 ADC Fault, Reverse Connection Fault)
Keep off	-	-	Standby/Sleep

## 1.4 PIN Definition

TGP-BAT-LV51-16 has 2 communication interfaces: COM1 and COM2, the PIN definition of COM ports are shown as follows.

**Table 5. The Communication Port Definition**

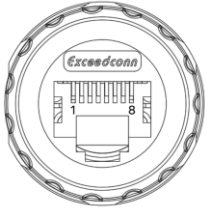
COM1/2	Pin	Description
 <p>COM 1</p>	1	RS485_B
	2	RS485_A
	3	CAN0-H (Batteries in parallel)
	4	CAN1-H (communicate with inverter)
	5	CAN1-L (communicate with inverter)
	6	/
	7	CAN0-L (Batteries in parallel)
	8	/
	1	RS485_B (Connecting UI-ware or inverter)

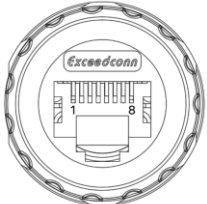

 <p>COM 2</p>	2	RS485_A Connecting UI-ware or inverter
	3	CAN0-H (Batteries in parallel)
	4	/
	5	/
	6	/
	7	CAN0-L (Batteries in parallel)
	8	/

## 1.5 Technical Specifications

The main technical specifications of TGP-BAT-LV51-16 are shown as follows.

**Table 6. TGP-BAT-LV51-16 Specifications**

No.	Items	Parameter
1	Nominal voltage	51.2 V
2	Nominal capacity	314 Ah
3	Nominal energy	16.07 kWh
4	Recommended charge voltage	57.6 V
5	Discharge cut-off voltage	42.0 V
6	Max. continuous charge current	150 A
7	Max. continuous discharge current	150 A
8	Communication	CAN/RS485
9	Battery quantity of parallel connection	≤15pcs
10	Operation temperature	Discharge -20°C ~ 60°C, Charge 0°C ~60°C
11	Recommended Storage temperature	0°C~40°C (Recommended 15°C~ 35°C)
12	Allowable relative humidity	5% ~ 95% Non-condensing
13	Altitude	2000m without derating
14	Protection level	IP65



No.	Items	Parameter
15	External Interface	Battery positive and negative power terminals: 2*P+, 2*P- Communication:2*RJ45
16	Installation method	Floor-standing
17	Display method	Indicator light (power, operation status)
18	Dimensions (W*H*D)	500±1.5 *860±1.5*250±1.5 mm (without cover and bracket)
19	Weight	Approx. 127±3 kg (Update when actual weight is available)

## 1.6 Recycling and Disposal

Failed batteries need to be recycled and disposed of according to local policies. Supplier can provide the recycling guideline about the lithium battery, which can help the end user to guide how to recycle and dispose the lithium battery.



## 2 Installation

### 2.1 Precautions for Installation

Installation, wiring, and commissioning must comply with all applicable national and local electrical codes, including the Canadian Electrical Code (CEC) and provincial/territorial regulations.

This product carries UL certification for product safety; installation compliance must be verified by licensed electricians and local authorities having jurisdiction (AHJ).

This manual is supplementary. In all cases, local regulations and AHJ requirements take precedence.

- Light intensity is required near the installation location.
- Comply with the safety operation technical regulations when lifting and handling heavy objects.
- Equipment and tools must be complete, intact, and reliable. It is strictly prohibited to use tools with cracks, burrs, loose handles, etc., that do not meet the safety standards.
- Installation operations must be guided by qualified engineers.
- During installation, two people must work together, one operating and the other inspecting.
- The original cable connection and operation process shall not change without the authorization of the company's consent.



### 2.2 Installation Preparation

#### 2.2.1 Tools Preparation





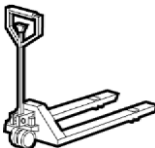

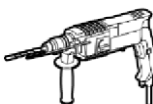



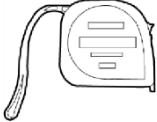
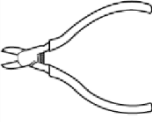

Insulated installation tools must be used to prevent electric shocks. If tools without insulation protection are used, the exposed metal parts must be wrapped and insulated with insulating tape.

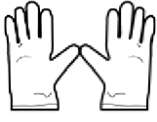
The following table shows tools that need to be prepared before installation.

**Table 7. Tools Preparation**

Electric forklift	Manual forklift	Electric screwdriver	Impact drill
			
Phillips screwdriver	Socket wrench	Insulated torque wrench	Tape measure



			
Diagonal pliers	Claw hammer	Multimeter	Anti-static gloves
			
Helmet	Goggle	Insulation shoes	Insulating tape
			
Diagonal pliers	Claw hammer	Multimeter	Anti-static gloves
			
Helmet	Goggle	Insulation shoes	Insulating tape

## 2.2.2 Packing List

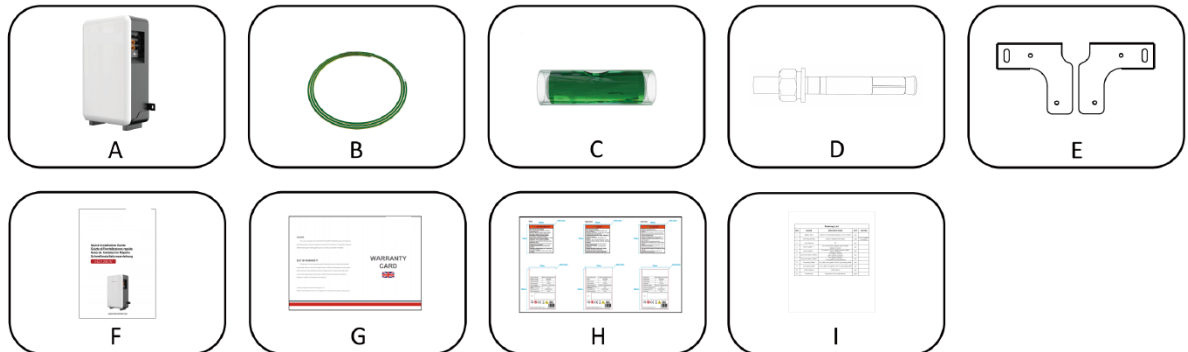

Table 8. Packing List

Item	Description	Quantity
A	TGP-BAT-LV51-16 battery	1
B	GND cable	1
C	Spirit Level (Optional)	1
D	Expansion Screws	2
E	Bracket	2
F	Quick Installation Guide	1
G	Warranty Card	1



H	Multilingual Specification Label (Optional)	1
I	Packing List	1

### 2.2.3 Unpacking and Inspection

After receiving the goods on-site, please check whether the packing box is intact and inspect the goods in time. If the packing box is slightly damaged, please sign the cargo list to confirm receipt and indicate the extent of the damage. If the damage of the packing box is serious, please refuse to sign.

Please carry out an unpacking inspection after receiving all the goods. If users find that the received goods do not match the packing list, please contact TuroGize as soon as possible.

## 2.3 Installation

Before installing the TGP-BAT-LV51-16, users need to plan the installation site. The installation site should comply with the following conditions:

- Please place the TGP-BAT-LV51-16 battery on a flat surface, ensuring there is adequate space on both sides of the battery (recommended to be greater than 400mm).
- If possible, the installation site should be as spacious and ventilated as possible. If the site is small and confined, please configure auxiliary heat dissipation equipment.

**Step 1.** Take out the TGP-BAT-LV51-16 and put it in a suitable installation place.

---

**⚠ATTENTION**

- **The battery is heavy. If possible, please use tools to assist in handling and installation.**
- 

To ensure more stable battery installation, please mount the battery to the wall before use.

**Step 2.** Fix the 2pcs brackets to the battery.

**Step 2.1.** Remove the screws from the back of the battery.

**Step 2.2.** Take out the 2pcs brackets from the battery package.

**Step 2.3.** Use the removed screws (Step 2.1) to fix the brackets to the back of the battery.

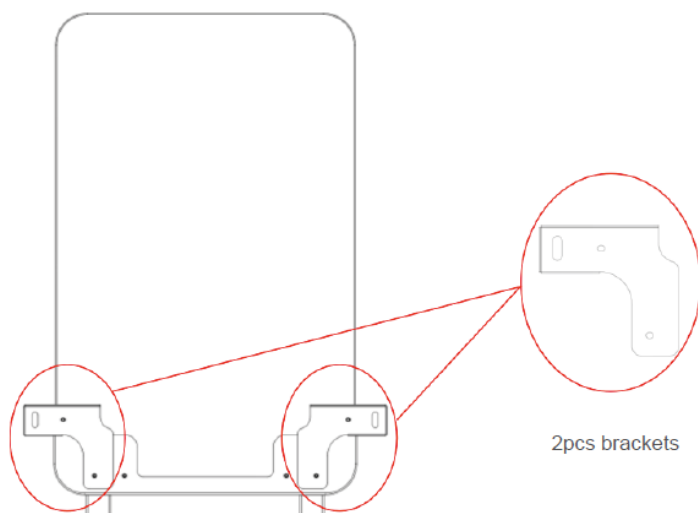

**Fig. 4 Fix the Brackets to the Battery**

**Step 3.** Fix the 2pcs\* 'Fixing screws' on the wall.

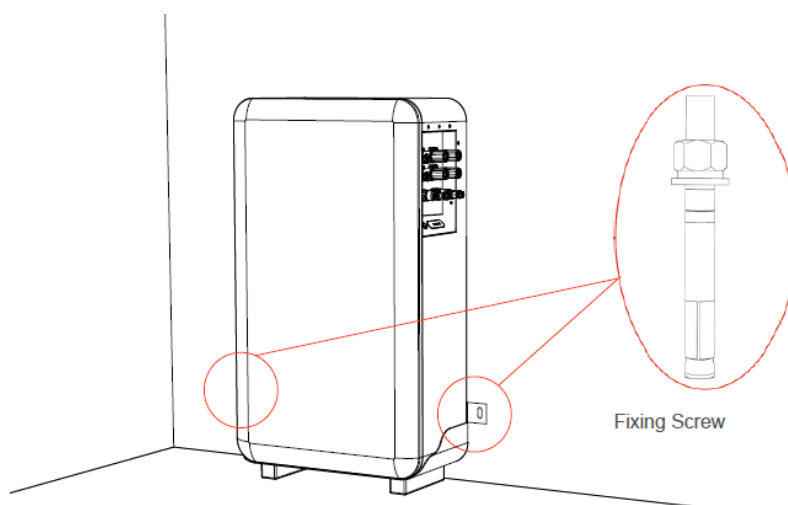
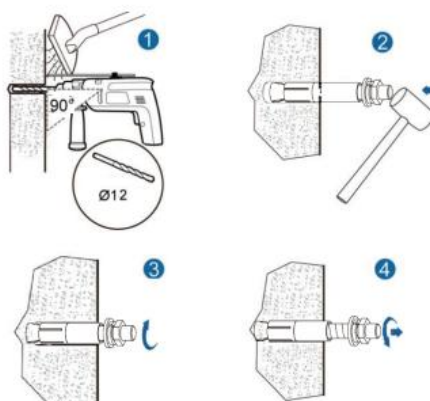
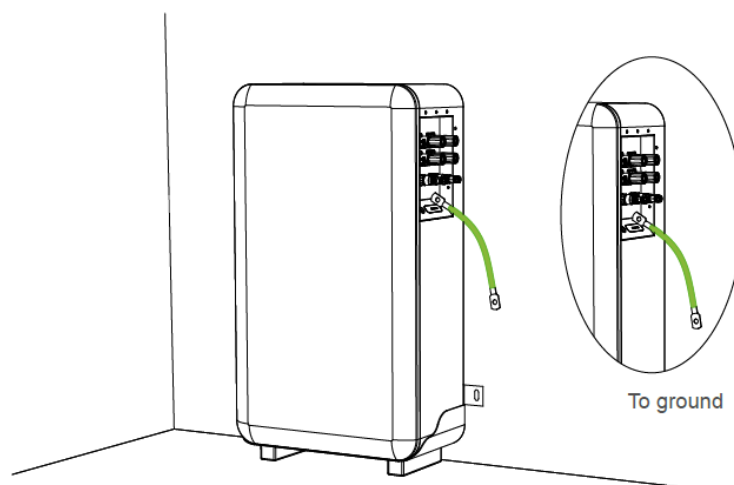

**Fig. 5 Fix the TGP-BAT-LV51-16**



---

**Step 4.** Connect the ground wire to the ground.



**Fig. 6** Grounding the TGP-BAT-LV51-16

## 2.4 Recommended Configuration

According to the power rating of the inverter, requiring a corresponding minimum quantity of batteries in parallel:

- When the inverter power  $\leq 8\text{kW}$ : need to configure at least one TGP-BAT-LV51-16 battery.
- When  $8\text{kW} < \text{inverter power} \leq 16\text{kW}$ : need to configure at least two TGP-BAT-LV51-16 batteries (connect in parallel).

## 2.5 Cable Connection

---

### NOTE

- Please contact TuroGize or the supplier to purchase the following cables. They are not included in the battery box and can be obtained in the Master/Slave Cable Kit provided by TuroGize or the suppliers.
- 

### 2.5.1 Power Cables Connection

---

#### ATTENTION

- During the operation, please use the insulation tools to prevent electric shocks.
- Please pay attention to the terminals' color of the battery: orange corresponds to the positive pole, and black corresponds to the negative pole.
- Before connecting power cables, please ensure that the inverter, battery and the bus bar are OFF.



- 
- Please connect the negative power cables (black) of all batteries first, and then connect the positive power cables (red) of all batteries.
- 

 NOTE

- **How to use the power cable connector.**

Press the lock on the power cable while inserting the power cable into the socket.

---



The following is the power cables connection display of the battery to the inverter.

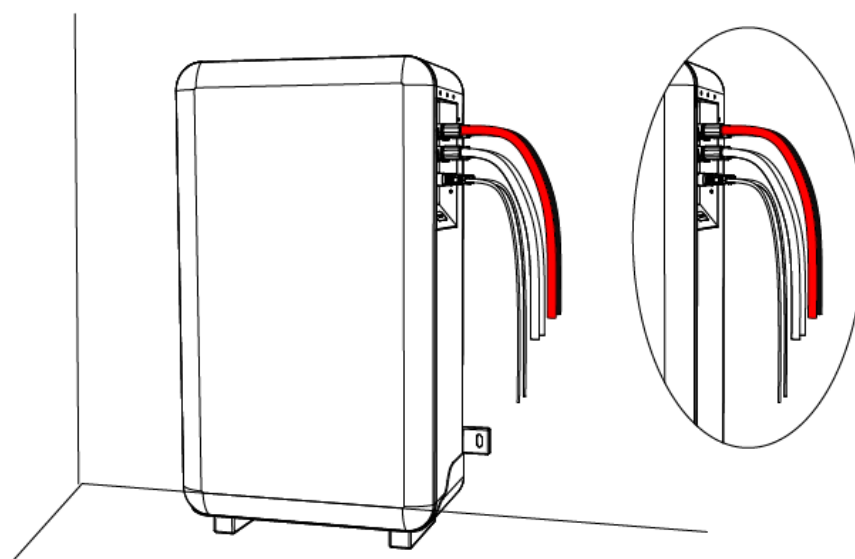

Fig. 7 Power Cable Connection Diagram

## 2.5.2 Communication Cable Connection

---

 NOTE

- **How to use the communication cable connector.**

Open the communication port cover, align it with the corresponding socket, and insert it.

---

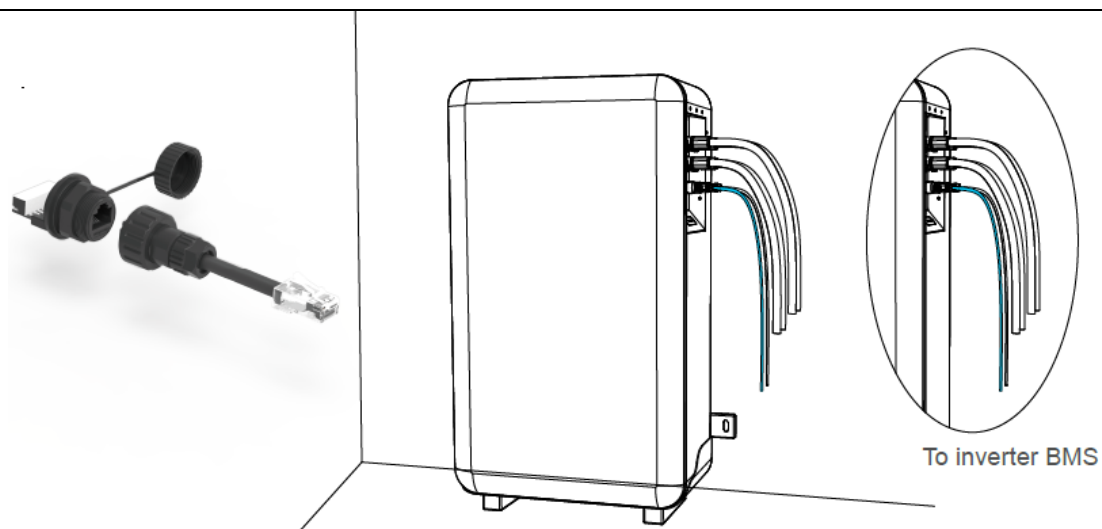

**Fig. 8 Communication Cable Connection Diagram**

**ATTENTION**

- Please pay attention to the direction when plugging the communication cable connector, do not operate violently.
- Communication cables and power cables must be routed separately.

### 2.5.3 120Ω Resistor Connection

To ensure stable communication with inverter when using more than two batteries in parallel, follow these steps:

**Step 1.** Take out 120Ω resistor from the 'Slave battery kit'.

**Step 2.** Insert the 120Ω resistor into the 'COM2' port of the last TGP-BAT-LV51-16 battery.



### 3 Parallel Connection

If you have several batteries that need to be connected in parallel, please refer to the following instructions.

#### NOTE

- Use a multimeter to confirm that the battery is powered off before wiring.
- It is recommended that a circuit breaker between the inverter and the battery be installed in accordance with local laws and regulations.

**Case 1. If you will install less than 2pcs batteries (Battery quantity  $\leq 2$ ), the max. output current of the system will be 150A which should be limited by inverter or external charger to prevent battery damage. Please refer to the following wiring configuration.**

Battery Quantity of Parallel	Cable Kit
1 pcs	Master Cable Kit * 1 set
2 pcs	Master Cable Kit * 1 set
	Slave Cable Kit * 1 set

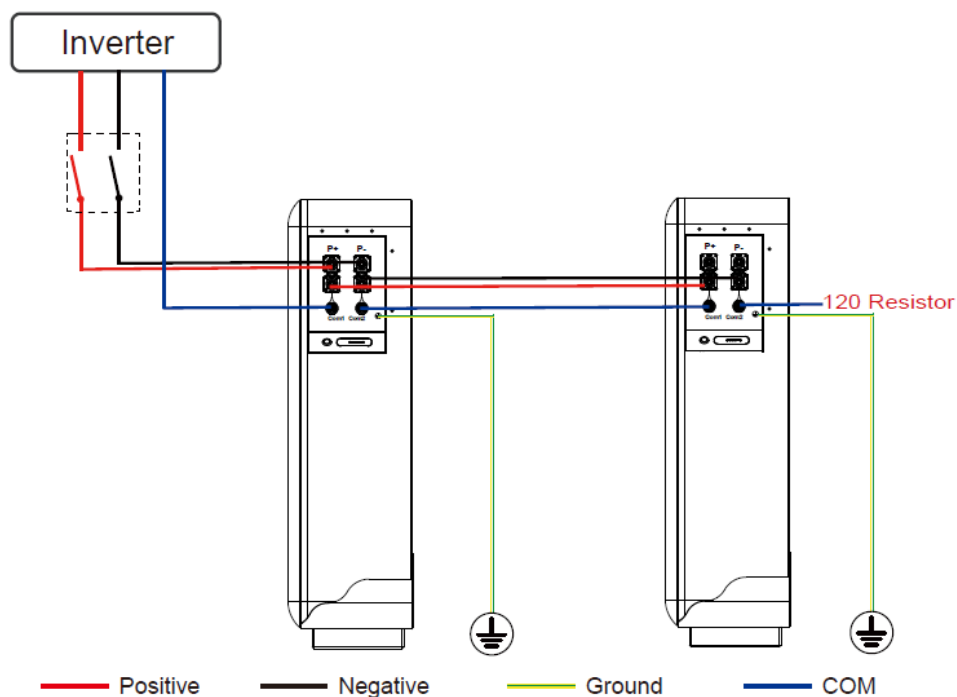

Fig. 9 2pcs Batterie in Parallel Connection Diagram



**Case 2. If you will install more than 2pcs batteries (No more than 15pcs) , you will have the following two system wiring options.**

**NOTE**

- For following wiring solution, you will need to prepare bus bars and power cables to connect the bus bars to the inverter in addition. You can either purchase them independently or obtain them from TuroGize or the supplier.

**Case 2.1. Connect all batteries to the bus bar.**

**In this wiring solution, the max. output current of the system will be 400A which should be limited and set in advance by inverter or external charger to prevent battery damage.**

Battery Quantity of Parallel	Cable Kit
3 pcs	Master Cable Kit * 3 set
4 pcs	Master Cable Kit * 4 set
5 pcs	Master Cable Kit * 5 set
.....	.....
15pcs	Master Cable Kit *15 set

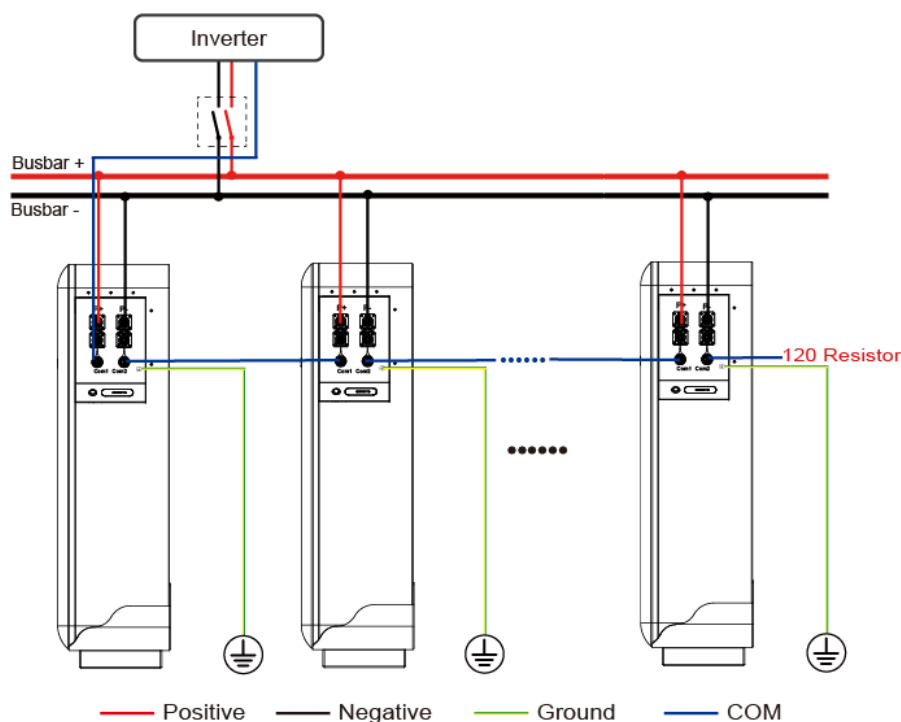

**Fig. 10 All batteries to the bus bar Connection Diagram**



**Case 2.2. Connect batteries by 'hand to hand'.**

**In this wiring solution, the max. output current of the system will be 300A which should be limited and set in advance by inverter or external charger to prevent battery damage.**

Battery Quantity of Parallel	Cable Kit
3 pcs	Master Cable Kit * 2 set
	Slave Cable Kit * 2 set
4 pcs	Master Cable Kit * 2 set
	Slave Cable Kit * 3 set
5 pcs	Master Cable Kit * 2 set
	Slave Cable Kit * 4 set
.....	.....
15pcs	Master Cable Kit * 2 set
	Slave Cable Kit * 14 set

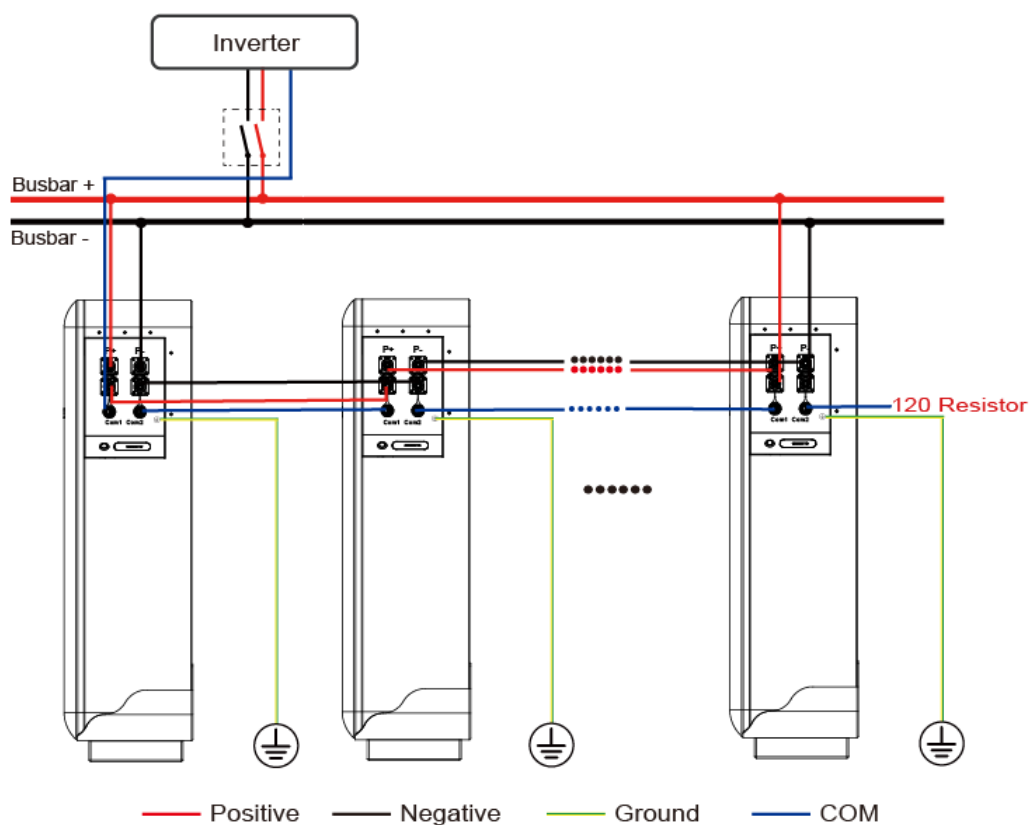

**Fig. 11 Batteries 'hand to hand' Connection Diagram**



---

## 4 Make System Run

---

### 4.1 Check before Running

**Step 1.** Check whether the cables are connected correctly and well.

**Step 2.** Check whether the batteries are grounded.

**Step 3.** Check these following status of switches.

- The power switch of the battery should be off.
- The DC switch of the inverter should be off.
- The circuit breaker from the inverter to the grid should be off.

---

#### ATTENTION

- Please strictly follow the steps below for check and operation. TuroGize will not be responsible for any issues caused by improper operation.
  - Battery parallel connection requirements: the Max. voltage difference between batteries should not exceed 2V or the SOC different don't exceed 30%.
  - When multiple batteries are connected in parallel, there is a communication delay between the whole battery system and the inverter. In the event that some batteries in the system disconnect, the remaining batteries need to distribute the original system's current within the delay time, which can result in damage to the BMS. Therefore, although we can support up to 15pcs in parallel, we can only support a total of 15pcs parallel connection within the 400A charging and discharging. In other words, even if the battery system exceeds 4pcs in parallel (but does not exceed 15pcs in parallel), the Max. charging and discharging of the battery system remains at 400A.
- 

### 4.2 Power-on

**Step 4.** Turn on the DC switch of inverter.

- Turn on the switch between the inverter and grid.
- Turn on the circuit breaker between the inverter and battery (if any).

**Step 5.** Turn on the power switch of battery. And waiting for the Run/Alarm indicator lights from green blinking into green, means power on successfully !



---

## 4.3 Power-off

If you need to shut down (Power-off) the whole system for some reason, please refer to the following steps.

**Step 1.** Turn off the inverter.

**Step 2.** Turn off the whole battery system then (wait at least 1 minute before re-turn on).

---

### NOTE

- TGP-BAT-LV51-16 has completed the system parameter settings at the factory, and the system will run automatically after power is on.
-



## 5 Maintenance

### ATTENTION

- The engineer personnel who perform the following operations must have received professional training. Before operating and maintaining the TGP-BAT-LV51-16 battery, please wear anti-static work clothes, anti-static gloves, and wrist straps, and remove conductive objects such as jewelry and watches to avoid electric shock or burns.
- When operations such as installation and maintenance only about the batteries, the power switch of the junction box and batteries should be kept OFF. If you want to operate the inverter, the power switch of the junction box, the power switch of the batteries, the power switch of the inverter, and the circuit breaker between the inverter and the grid should be kept OFF.

### 5.1 Battery Storage

- The recommended storage temperature is 15°C~35°C.
- TGP-BAT-LV51-16 performance degradation after long-term storage, please shorten shelf time as possible as you can.
- Charge before using to recover capacity loss of self-discharge during storage and transport.
- Storage batteries should be at 40%-50% SOC when it is not used for a long time.
- Storage batteries over 40°C or under 0°C will reduce battery life. Store batteries in a dry and low-temperature, well-ventilated place.
- When the battery is exposed to temperatures below 0°C, please fully charge the battery and stop using it. If you continued to use the battery under such conditions, it will significantly reduce the battery's cycle life. TuroGize will not be responsible for warranty claims if the battery is used in such conditions.

If the TGP-BAT-LV51-16 is not used for a long time, it must be charged at regular intervals. The regular charging requirements are as follows:

**Table 9. TGP-BAT-LV51-16 Charge Requirement in Storage Status**

Battery Remaining SOC	Storage Temperature	Charge Period	Charge Requirement
55%±5%	-10°C~30°C	Every 6 months	1.Charge by 0.2C to 100% SOC 2.Discharge by 0.2C to 0% SOC 3.Charge by 0.2C to 40%~50% SOC
	30°C~40°C	Every 3 months	
30%±5%	-10°C~30°C	Every 3 months	1.Charge by 0.2C to 100% SOC 2.Discharge by 0.2C to 0% SOC 3.Charge by 0.2C to 40%~50% SOC
	30°C~40°C	Every 1 months	



## 5.2 Monthly Maintenance

Users should conduct a visual inspection of the TGP-BAT-LV51-16 monthly. Please refer to the following table for monthly maintenance.

**Table 10. Monthly Maintenance**

Item	Refer Standard	Suggestion for Abnormal Issue
Battery appearance	<ul style="list-style-type: none"><li>● The appearance is neat and clean without stains.</li><li>● The TGP-BAT-LV51-16 terminals are intact.</li><li>● The TGP-BAT-LV51-16 shell is intact, and there are no bumps, breaks, or cracks around it.</li><li>● The appearance of battery has no leakage.</li><li>● There is no deformation or bulging of the shell.</li></ul>	<ul style="list-style-type: none"><li>● If there is dirt on the surface, clean the TGP-BAT-LV51-16's appearance with a cotton cloth.</li><li>● If the appearance is damaged, leaking, or deformed, take a photo and replace the defected TGP-BAT-LV51-16.</li><li>● Please contact TuroGize in time for other abnormal situations.</li></ul>
Operation environment	The operation environment is between 0°C-45°C. Operation humidity range: ≤95% RH.	If temperature and humidity are abnormal, check the indoor air conditioner status.

## 5.3 Quarterly Maintenance

Please refer to the following table for the quarterly maintenance of TGP-BAT-LV51-16.

**Table 11. Quarterly Maintenance**

Item	Refer Standard	Suggestion for Abnormal Issue
Cable	There is no aging of the connecting cable and no cracking of the insulation layer. The bolts at the cable connection are not loose.	Replace the faulty cable. Fasten the screws.

## 5.4 Yearly Maintenance

It is recommended to perform trend analysis on recorded data (battery and environment).



---

## 6 Shipment

---

It is suitable for the transportation of vehicles, ships and airplanes. During transportation, shading, sun protection and civilized loading and unloading should be performed. The box containing the product is allowed to be transported by any means of transportation. In the process of loading and unloading, the battery should be handled with care to prevent falling, rolling, and heavy pressure. Avoid direct rain and snow and mechanical impact during transportation.

And here is the suggestion for the initial SOC before shipment by different transportation:

- Airplane: 30%
- Sea :50%
- Vehicle:50%

---

### NOTE

- **Whether the loading SOC status of the battery is allowed, you need to consult the relevant government transportation department.**
-



## 7 Troubleshooting

Please refer to the table below to deal with common faults:

**Table 12. FAQ**

Issue	Possible cause	Solution
The indicator does not flash	<ul style="list-style-type: none"><li>● The power cable of the battery pack is not properly connected.</li><li>● The power switch is off.</li><li>● The BMS is in a sleep state.</li><li>● BMS is damaged.</li></ul>	<ul style="list-style-type: none"><li>● Reconnect the power cable of the battery pack.</li><li>● Turn on the power switch.</li><li>● Charge the battery pack.</li><li>● Replace BMS.</li></ul>
Unable to discharge	<ul style="list-style-type: none"><li>● The terminal of the battery pack is damaged.</li><li>● BMS communication failure.</li><li>● The power switch is off.</li></ul>	<ul style="list-style-type: none"><li>● Replace the battery pack wiring terminals.</li><li>● Reconnect the communication line between the BMS and the battery pack. If the communication cable is damaged, replace the communication cable.</li><li>● Turn on the power switch.</li></ul>
Unable to charge	<ul style="list-style-type: none"><li>● The charger is malfunctioning.</li><li>● The terminal of the battery pack is damaged.</li><li>● BMS communication failure.</li><li>● The power switch is off.</li></ul>	<ul style="list-style-type: none"><li>● Replace the charger.</li><li>● Replace the battery pack wiring terminals.</li><li>● Reconnect the communication line between the BMS and the battery pack. If the communication cable is damaged, replace the communication cable.</li><li>● Turn on the power switch.</li></ul>
Communication fail	<ul style="list-style-type: none"><li>● The power switch is off.</li><li>● The BMS is in a sleep status.</li><li>● The communication cable is damage.</li></ul>	<ul style="list-style-type: none"><li>● Turn on the power switch.</li><li>● Charge the battery pack.</li><li>● Replace the network cable.</li></ul>
Inaccurate voltage display	<ul style="list-style-type: none"><li>● The voltage sampling line is damaged.</li><li>● BMS is damaged.</li></ul>	<ul style="list-style-type: none"><li>● Replace the voltage sampling line.</li><li>● Replace BMS.</li></ul>
Low capacity	<ul style="list-style-type: none"><li>● The battery pack has not been maintained for a long time.</li><li>● The single battery is damaged.</li><li>● Inaccurate voltage sampling.</li></ul>	<ul style="list-style-type: none"><li>● Use an equalizer to maintain the battery pack.</li><li>● Replace the damaged single battery.</li><li>● Replace the electrical sampling line or replace the BMS.</li></ul>
Low cell voltage	<ul style="list-style-type: none"><li>● The battery pack has not been maintained for a long time.</li><li>● The single battery is damaged.</li><li>● Inaccurate voltage sampling.</li></ul>	<ul style="list-style-type: none"><li>● Use an equalizer to maintain the battery pack.</li><li>● Replace the damaged single battery.</li><li>● Replace the electrical sampling line or replace the BMS.</li></ul>

Note: If further support required, please contact customer service: [support@turogize.com](mailto:support@turogize.com)



---

## 8 Warranty

---

This Limited Warranty covers defects in materials and workmanship under normal residential use for a period of 10 years from the date of purchase.

Warranty service may include repair or replacement of defective components.

TuroGize as the brand owner, the warranty service is delivered through the authorized service partners and technical support channels.

### Conditions for Warranty Validity

The warranty remains valid only if all the following conditions are met:

1. The product is properly installed, wired, and commissioned in accordance with:
  - Canadian Electrical Code (CEC)
  - Provincial/territorial regulations
  - Local authorities having jurisdiction (AHJ)
2. Installation is performed by licensed electricians.
3. Installation and operation follow the User Manual and remain within all specified operating limits.
4. The battery is used in compatible systems and with approved accessories.
5. The product's configuration, software, and firmware must remain unchanged and be updated solely through official TuroGize channels (App Store / Google Play).
6. The product label and serial number remain intact and unaltered.

### Warranty Exclusions

This warranty applies only to defects in the product itself. It does not apply to the following situations:

- Damage caused by improper installation, wiring, or configuration
- Damage resulting from failure to comply with electrical codes or AHJ requirements
- Use outside product specifications (temperature limits, SOC limits, parallel limits, etc.)
- Use with third-party equipment not approved by TuroGize.
- Physical damage during the user application, due to moving, dropping, or other shock
- Damage caused by environmental exposure beyond the product's specified limits (salets, chemicals, etc.)
- Unauthorized disassembly, modification, or repair
- Damage caused by fire, flood, lightning, power surges, utility grid issues, or other force majeure events
- Capacity loss or normal aging of the battery
- Costs related to labor, transportation, or removal/reinstallation unless otherwise specified



---

## Abbreviations

---

BMS	Battery Management System
SOC	State of Charge
SOH	State of Health
D	Depth
H	Height
W	Width
LFP	LiFePO <sub>4</sub>
PC	Personal Computer



Address: 160 Cochrane Drive, Markham, ON L3R 9S1, Canada

Website: <http://www.TuroGize.com>

Service Email: [support@turogize.com](mailto:support@turogize.com)